



vision
trimline



WELCOME

The ability to control fire was a dramatic change in the development of humanity. Among many things it provided warmth, light and security. We believe this base connection still exists and is the reason why we still desire to use the fireplace as the central focal point of our living space.

The Vision Trimline range has been designed with the specific purpose of recreating that instinctive connectivity with nature.

Our innovative fires are skilfully engineered to allow a trimless aspect with no distracting frames or visible workings, just fire. These highly efficient beautifully designed appliances are available in a variety of different sizes and can be positioned in virtually any part of your home.

myfire® | MERTIK MAXITROL® | thermoCet

TL38	4 - 7
TL55XH	8 - 11
TL60CF	12 - 15
TL64	16 - 19
TL70SL	20 - 25
TL73/TL73H	26 - 31
TL83	32 - 37
TL85	38 - 41
TL100	42 - 47
TL120	48 - 53
TL140	54 - 59
TL170/TL170H	60 - 63
TL2050	64 - 67
GEMSTONE COLLECTION	68 - 85
TECHNOLOGY	86
INTERIOR STYLING & FUEL BED OPTIONS	88 - 89
TL70SL UPGRADE OPTIONS	90
FLUE SYSTEMS	91
DIMENSIONS	92 - 106

TL38



TL38

FRONT | CORNER | PANORAMIC

The TL38 balanced flue fire is one of the smaller appliances within the range, making even the smallest room feel cosy and inviting. It creates a luxury ambience with a single press of a button. With its realistic fuel bed and flame pattern, it makes a perfect choice for smaller properties.

WHAT'S INCLUDED:

- High Definition Logs
- Lamel Interior
- Single Burner
- Ecomax Remote Control
- Convection Vents
- Adjustable Legs
- Gas Control Box

OPTIONAL EXTRAS:

- Anti-Reflective Glass
- WiFi Kit
- Remote Control Wall Mount
- Mains Adaptor
- Wide Trims on Corner and Panoramic models only

Fuel Bed Options:

- Pebbles

TECHNICAL INFO:

GAS TYPE	NG	LPG
HEAT INPUT (kW)	6.4	6.2
HEAT OUTPUT MAX (kW)	5.2	5.2
HEAT OUTPUT MIN (kW)	2.8	2.5
EFFICIENCY (%)*	82	84
FLUE SIZE (MM)	100/150	100/150
ERP RATING	B	B



TL38 FRONT



TL38 CORNER

TL55XH



TL55XH

FRONT | TUNNEL

The Triline 55XH Front and the 55XH Tunnel built-in fire is the first vertical model in the range and is 1.1 meters high. This appliance will certainly create a statement piece in any home. The standard version has a burner bed made of high definition logs and is equipped with a double burner. There is also an option to include a built-in LED bed to add even more ambiance.

WHAT'S INCLUDED:

- Burning Log Fuel Bed
- Lamel Interior
- Ecomax Remote Control
- Convection Vents
- Control Access Door
- Gas Control Box

OPTIONAL EXTRAS:

- Anti-reflective Glass
- Wifi Kit
- Remote Control Wall Mount
- Mains Adaptor

Fuel Bed Options:

- LED Glowing Fuel Bed

TECHNICAL INFO:

GAS TYPE	NG	LPG
HEAT INPUT (kW)	12.7	12.2
HEAT OUTPUT MAX (kW)	10.3	9.8
HEAT OUTPUT MIN (kW)	3.8	3.2
EFFICIENCY (%)*	81	80
FLUE SIZE (MM)	130/200	130/200
ERP RATING	C	C



TL55XH FRONT



TL55XH TUNNEL

TL60CF



TL60CF

TL60CF

If your home features a conventional brick chimney and you wish to utilise this, then we have that covered with our TL60CF appliance. Like our balanced flue appliances, the TL60CF can be fitted with or without a variety of fireplace mantels to create a truly unique focal point to your living space.

WHAT'S INCLUDED:

- High Definition Logs
- Flat Steel Interior
- Ecomax Remote Control
- Adjustable Legs

OPTIONAL EXTRAS:

- Anti-Reflective Glass
- WiFi Kit
- Remote Control Wall Mount
- Mains Adaptor



TECHNICAL INFO:

GAS TYPE	NG	LPG
HEAT INPUT (kW)	6.8	6.4
HEAT OUTPUT MAX (kW)	5.1	4.8
HEAT OUTPUT MIN (kW)	2.5	2.9
EFFICIENCY (%)*	75	76
FLUE SIZE (MM)	100	100
ERP RATING	D	D



TL64



TL64

FRONT | PANORAMIC | CORNER

Look no further than the TL64 which will fit perfectly with virtually all interiors. It can transform the smallest of living spaces into a modern contemporary space. The balanced flue gas fire incorporates the latest burning log technology. This innovative feature is so realistic it cannot be distinguished from a natural living fire. With the addition of the optional glowing fuel bed, it creates a beautiful warm ambience!

WHAT'S INCLUDED:

- Burning Log Fuel Bed
- Anthracite Steel Interior
- Double Burner
- Ecomax Remote Control
- Convection Vents
- Adjustable Legs
- Gas Control Box

OPTIONAL EXTRAS:

- Anti-Reflective Glass
- WiFi Kit
- Remote Control Wall Mount
- Mains Adaptor
- Wide Trims
- Wall Bracket

Fuel Bed Options:

- LED Glowing Fuel Bed

Interior Options:

- Black Glass
- Interior Grey Brick
- Reeded Panel

TECHNICAL INFO:

GAS TYPE	NG	LPG
HEAT INPUT (kW)	9.5	11.2
HEAT OUTPUT MAX (kW)	7.7	9.2
HEAT OUTPUT MIN (kW)	3.2	2.8
EFFICIENCY (%)*	82	82
FLUE SIZE (MM)	130/200	130/200
ERP RATING	B	B



TL64 PANORAMIC



TL64 FRONT

TL70SL

With an innovative, versatile design the compact TL70SL is easy to install and simple to service. The TL70SL can be wall mounted and installed directly to any internal outside facing wall.

One of the biggest advantages is that there is minimal building work required and with an output of 3.8kW and an impressive efficiency rating of B, the TL70SL will fit perfectly with virtually all interiors with sleek lines for a contemporary living statement.

The TL70SL utilises the same features as the other appliances within the range. The TL70 is remotely operated and to alleviate the need for batteries a mains adaptor is supplied as standard.



TL70SL

FRONT | INTEGRATED HEATBOX | PANACEA | HAMPTON |
RADLEY | RICO

With an innovative, versatile design the compact TL70SL is easy to install & simple to service. It can be wall-mounted & installed directly to any internal outside-facing wall.

WHAT'S INCLUDED:

- High Definition Logs
- Lamel Interior
- Ecomax Remote Control
- Mains Adaptor
- Wall Terminal
- Terminal Flue Guard

OPTIONAL EXTRAS:

- Anti-Reflective Glass
- WiFi Kit
- Remote Control Wall Mount

Interior Options:

- Black Glass
- Vermiculite



TL70SL PANACEA

TECHNICAL INFO:

GAS TYPE	NG	LPG
HEAT INPUT (kW)	4.5	5.0
HEAT OUTPUT MAX (kW)	3.8	3.3
HEAT OUTPUT MIN (kW)	2.8	2.0
EFFICIENCY (%)*	84	83
FLUE SIZE (MM)	100/150	100/150
ERP RATING	B	B



TL64 HAMPTON

TL70SL RADLEY SUITE WITH SHELF



TL70SL WITH INTEGRATED HEAT BOX

When the TL70SL is installed with our new bespoke Integrated Heat Box (IHB) it allows you to construct the installation from combustible materials making the fire a versatile choice in most modern building applications.

The use of the integrated heat box allows the appliance to be installed in situations where combustible surfaces or materials would or may hinder the installation given the risk of heat and allows quicker access for service and maintenance.

WHAT'S INCLUDED:

- Easy to install & simple to service
- Can be fitted with the use of combustible materials* when installing with the Integrated Heat Box
- Slimline appliance only 155mm depth
- Can be wall mounted or installed within a suite
- Can be installed directly to any internal outside facing wall
- Energy class B – 84% efficient
- Can be installed into a cavity wall
- Realistic log effect
- Comes complete with mains adaptor

*Please refer to installation instructions when fitting with or without the Integrated Heat Box.

TL70SL RICO SUITE



TL70SL WITH INTEGRATED HEAT BOX



TL73/TL73H



TL73H FRONT

TL73/TL73H

FRONT | TUNNEL | ROOM DIVIDER

The TL73 Front allows you to create a minimalist look which will fit perfectly with virtually all interiors. The wide glass front allows unrestricted views of the beautiful flames.

WHAT'S INCLUDED:

- High Definition Logs
- Lamel Interior on TL73 model only
- Anthracite Steel Interior on TL73H, Room Divider and Tunnel models only
- Ecomax Remote Control
- Convection Vents
- Adjustable Legs
- Gas Control Box

OPTIONAL EXTRAS:

- Anti-Reflective Glass
- WiFi Kit
- Remote Control Wall Mount
- Mains Adaptor
- Wide Trims

Fuel Bed Options:

- Pebbles

Interior Options*:

**Available on TL73H models only*

- Black Glass
- Vermiculite
- Fire Brick

TECHNICAL INFO:

GAS TYPE	NG	LPG
HEAT INPUT (kW)	11.4	8.8
HEAT OUTPUT MAX (kW)	10.1	7.6
HEAT OUTPUT MIN (kW)	3.1	2.6
EFFICIENCY (%)*	89	86
FLUE SIZE (MM)	130/200	130/200
ERP RATING	A	B



TL73 FRONT



TL73H ROOM DIVIDER

TL73H FRONT



TL73H TUNNEL



TL73 ROOM DIVIDER

TL83



TL83

FRONT | PANORAMIC | CORNER | TUNNEL | ROOM DIVIDER

The stunning TL83 available in Front, Tunnel, Corner and Panoramic options. The TL83 incorporates the latest burning log technology. This innovative feature is so realistic it cannot be distinguished from a natural living fire. With the addition of the optional glowing fuel bed, it creates a beautiful warm ambience.

WHAT'S INCLUDED:

- Burning Log Fuel Bed
- Anthracite Steel Interior
- Double Burner
- Ecomax Remote Control
- Convection Vents
- Adjustable Legs
- Gas Control Box

OPTIONAL EXTRAS:

- Anti-Reflective Glass
- WiFi Kit
- Remote Control Wall Mount
- Mains Adaptor

Fuel Bed Options:

- LED Glowing Fuel Bed

Interior Options:

- Black Glass
- (not available on TL83 Tunnel)
- Interior Grey Brick (not available on TL83 Room Divider)
- Black Groove

TECHNICAL INFO:

GAS TYPE	NG	LPG
HEAT INPUT (kW)	11.5	11.9
HEAT OUTPUT MAX (kW)	9.4	9.8
HEAT OUTPUT MIN (kW)	2.6	2.6
EFFICIENCY (%)*	82	82
FLUE SIZE (MM)	130/200	130/200
ERP RATING	B	B

TL83 ROOM DIVIDER



TL83 TUNNEL





TL83 FRONT



TL83 PANORAMIC

TL85



TL85

ROOM DIVIDER

Our state of the art TL85 landscape room divider will create an impact in any living space. This three-sided gas appliance can also be used between multiple rooms allowing you to view the fire from all three sides.

WHAT'S INCLUDED:

- High Definition Logs
- Lamel Interior
- Single Burner
- Ecomax Remote Control
- Convection Vents
- Adjustable Legs
- Gas Control Box

OPTIONAL EXTRAS:

- Anti-Reflective Glass
- WiFi Kit
- Remote Control Wall Mount
- Mains Adaptor
- Wide Trims

Fuel Bed Options:

- Pebbles
- Carrara
- Basalt

TECHNICAL INFO:

GAS TYPE	NG	LPG
HEAT INPUT (kW)	9.9	8.9
HEAT OUTPUT MAX (kW)	8.1	7.3
HEAT OUTPUT MIN (kW)	3.0	2.5
EFFICIENCY (%)*	82	82
FLUE SIZE (MM)	130/200	130/200
ERP RATING	B	B

TL85 ROOM DIVIDER



TL100



TL100 CORNER

TL100

FRONT | PANORAMIC | CORNER | TUNNEL

Create a stylish home with the TL100 appliance. It is one of four of the larger elegantly styled landscaped balanced flue gas fires in the Vision Trimline range. The TL100 is all about luxury and suits a wide range of interiors. The double burner creates a beautifully vibrant fire while minimising energy consumption.

WHAT'S INCLUDED:

- High Definition Logs
- Lamel Interior on Front, Panoramic, and Corner models only
- Anthracite Steel Interior on Tunnel models only
- Double Burner
- Ecomax Remote Control
- Convection Vents
- Adjustable Legs
- Gas Control Box

OPTIONAL EXTRAS:

- Anti-Reflective Glass
- WiFi Kit
- Remote Control Wall Mount
- Mains Adaptor
- Wide Trims

Fuel Bed Options:

- Pebbles
- Carrara
- Basalt

Interior Options*:

**not available on the TL100 Tunnel model*

- Black Glass Panel

TECHNICAL INFO:

GAS TYPE	NG	LPG
HEAT INPUT (kW)	11.1	9.3
HEAT OUTPUT MAX (kW)	9.3	7.8
HEAT OUTPUT MIN (kW)	2.5	2.0
EFFICIENCY (%)*	84	84
FLUE SIZE (MM)	130/200	130/200
ERP RATING	B	B





TL100 FRONT



TL120



TL120

FRONT | PANORAMIC | CORNER | TUNNEL

The TL120 is one of four of the larger elegantly styled landscaped balanced flue gas fires in the Vision Trimline range which will fit seamlessly in a range of interiors. It is particularly suited to modern interior design styles. Liven up your home with a single press of a button. The standard version comes complete with high-definition logs and a lamel interior. On top of that, it comes with the Ecomax remote control and you have the options of adding Wi-Fi control with our Trimline Fires app.

WHAT'S INCLUDED:

- High Definition Logs
- Lamel Interior on Front, Panoramic, Corner models only
- Anthracite Steel Interior on Tunnel model only
- Double Burner
- Ecomax Remote Control
- Convection Vents
- Adjustable Legs
- Gas Control Box

OPTIONAL EXTRAS:

- Anti-Reflective Glass
- WiFi Kit
- Remote Control Wall Mount
- Mains Adaptor
- Wide Trims

Fuel Bed Options:

- Pebbles
- Carrara
- Basalt

Interior Options*:

**not available on the TL120 Tunnel model*

- Black Glass

TECHNICAL INFO:

GAS TYPE	NG	LPG
HEAT INPUT (kW)	11.3	9.8
HEAT OUTPUT MAX (kW)	9.5	8.3
HEAT OUTPUT MIN (kW)	2.5	2.0
EFFICIENCY (%)*	84	85
FLUE SIZE (MM)	130/200	130/200
ERP RATING	B	B



TL120 CORNER



TL120 PANORAMIC



TL140



TL140 TUNNEL

TL140

FRONT | PANORAMIC | CORNER | TUNNEL

Are you looking for an extra little something? Add a touch of elegance and luxury with the TL140. The standard version of this appliance comes with high-definition logs which creates beautifully vibrant flames while limiting the amount of heat generated. On top of that, it comes with the Ecomax remote control and you have the options of adding Wi-Fi-control with our Trimline Fires app.

WHAT'S INCLUDED:

- High Definition Logs
- Lamel Interior
- Double Burner
- Ecomax Remote Control
- Convection Vents
- Adjustable Legs
- Gas Control Box

OPTIONAL EXTRAS:

- Anti-Reflective Glass
- WiFi Kit
- Remote Control Wall Mount
- Mains Adaptor
- Wide Trims

Fuel Bed Options:

- Pebbles
- Carrara
- Basalt

Interior Options*:

- *not available on the Tunnel model*
- Black Glass Panel

TECHNICAL INFO:

GAS TYPE	NG	LPG
HEAT INPUT (kW)	13.8	12.7
HEAT OUTPUT MAX (kW)	11.0	10.2
HEAT OUTPUT MIN (kW)	4.5	3.9
EFFICIENCY (%)*	80	81
FLUE SIZE (MM)	130/200	130/200
ERP RATING	B	B

TL140 FRONT



TL140 PANORAMIC





TL140 CORNER



TL140 TUNNEL

TL170/TL170H



TL170/TL170H

FRONT

The TL170/TL170H is one of four of the larger elegantly styled landscaped balanced flue gas fires in the Vision Trimline range. This gas fire will add a touch of elegance and sophistication to any room. Meticulous attention has been paid to the realisation of the fuel bed and flame patterns to ensure a perfect recreation of a natural living fire.

WHAT'S INCLUDED:

- High Definition Logs
- Double Burner
- Lamel Interior
- Ecomax Remote Control
- Convection Vents
- Adjustable Legs
- Gas Control Box

OPTIONAL EXTRAS:

- Anti-Reflective Glass
- WiFi Kit
- Remote Control Wall Mount
- Mains Adaptor
- Wide Trims

Fuel Bed Options:

- Pebbles
- Carrara
- Basalt

Interior Options:

- Black Glass Interior

TECHNICAL INFO:

GAS TYPE	NG		LPG	
	TL170	TL170H	TL170	TL170H
FIRE TYPE				
HEAT INPUT (kW)	15.3	14.1	15.1	14.3
HEAT OUTPUT MAX (kW)	12.0	11.6	12.4	11.7
HEAT OUTPUT MIN (kW)	3.5	4.3	3.0	4.7
EFFICIENCY (%)*	82	82	82	82
FLUE SIZE (MM)	130/200	130/200	130/200	130/200
ERP RATING	B	B	B	B



TL170 FRONT



TL170H FRONT

TL2050



TL2050

PANORAMIC

Are you looking for a unique look? The stylish TL2050 On The Corner will turn your L-shaped living room into a work of art. Light up your life with this fireplace and will make the room come alive with the single push of a button.

WHAT'S INCLUDED:

- High Definition Logs
- Anthracite Steel Interior
- Single Burner
- Ecomax Remote Control
- Convection Vents
- Adjustable Legs
- Gas Control Box

OPTIONAL EXTRAS:

- Anti-Reflective Glass
- WiFi Kit
- Remote Control Wall Mount
- Mains Adaptor

TECHNICAL INFO:

GAS TYPE	NG	LPG
HEAT INPUT (kW)	8.7	8.2
HEAT OUTPUT MAX (kW)	7.3	6.8
HEAT OUTPUT MIN (kW)	2.8	2.5
EFFICIENCY (%)*	84	83
FLUE SIZE (MM)	100/150	100/150
ERP RATING	B	B

TL2050



GEMSTONE COLLECTION



TRIMLINE BLACK QUARTZ

The Trimline Quartz is proof you do not need a large home to have a freestanding gas fireplace. This is a beautiful, very lavish freestanding eyecatcher, adding special ambience to any room.

WHAT'S INCLUDED:

- High Definition Logs
- Lamel Interior
- Single Burner
- Ecomax Remote Control

OPTIONAL EXTRAS:

- Anti-Reflective Glass
- Wifi Kit
- Remote Control Wall Mount
- Mains Adaptor

TECHNICAL INFO:

GAS TYPE	NG	LPG
HEAT INPUT (kW)	6.4	6.2
HEAT OUTPUT MAX (kW)	5.2	5.2
HEAT OUTPUT MIN (kW)	2.8	2.5
EFFICIENCY (%)*	82	84
FLUE SIZE (MM)	100/150	100/150
ERP RATING	B	B



TRIMLINE WHITE QUARTZ

A freestanding, compact, and very stylish gas fireplace, suitable for even the smallest rooms. The Trimline Quartz is proof you don't need a large home to have a freestanding gas fireplace. This lavish freestanding appliance will add a special ambiance to any room. This White Quartz can also be installed on narrow walls. Sit down, relax and enjoy the playful flames of the White Quartz.

WHAT'S INCLUDED:

- High Definition Logs
- Lamel Interior
- Ecomax remote control

OPTIONAL EXTRAS:

- Anti-reflective Glass
- Wifi Kit
- Remote Wall Bracket
- Mains Adaptor

TECHNICAL INFO:

GAS TYPE	NG	LPG
HEAT INPUT (kW)	6.4	6.2
HEAT OUTPUT MAX (kW)	5.2	5.2
HEAT OUTPUT MIN (kW)	2.8	2.5
EFFICIENCY (%)*	82	84
FLUE SIZE (MM)	100/150	100/150
ERP RATING	B	B



TRIMLINE ZIRCON

The Trimline Zircon is our smallest freestanding fire. Unique in its kind. Like small gemstones dazzling in its beauty. The rounded corners and its open character give the fireplace a playful appearance. Create your own unique look. For a whimsical touch, add wooden blocks to the open bottom. The possibilities are endless. Try and discover your unique fireplace.

WHAT'S INCLUDED:

- Burning Log Fuel Bed
- Black Glass Interior
- Single Burner
- Ecomax Remote Control

OPTIONAL EXTRAS:

- Wifi Kit
- Remote Control Wall Mount
- Mains Adaptor

TECHNICAL INFO:

GAS TYPE	NG	LPG
HEAT INPUT (kW)	4.6	5.4
HEAT OUTPUT MAX (kW)	3.9	4.3
HEAT OUTPUT MIN (kW)	2.9	2.8
EFFICIENCY (%)*	84	80
FLUE SIZE (MM)	100/150	100/150
ERP RATING	B	C



TRIMLINE TOURMALINE

The Tourmaline is not just a fireplace. The panoramic view of the flames, the burning logs and the LED fuel bed bring you into an atmospheric environment. The Tourmaline has beautifully rounded corners. In combination with its smooth lines, it turns out to be a beautiful model that is a joy to the eye. You have the option of leaving the bottom of the fireplace open for stools. But you can also add a unique and stylish statement.

WHAT'S INCLUDED:

- Burning Log Fuel Bed
- Anthracite Steel Interior
- Double Burner
- Ecomax Remote Control

OPTIONAL EXTRAS:

- Anti-reflective Glass
- Wifi Kit
- Remote Control Wall Mount
- Mains Adaptor
- Wood Stool
- Fire Stool

Interior Options:

- Black Glass Interior
- LED Fuel Bed

TECHNICAL INFO:

GAS TYPE	NG	LPG
HEAT INPUT (kW)	6.8	6.5
HEAT OUTPUT MAX (kW)	5.3	5.2
HEAT OUTPUT MIN (kW)	3.7	3.8
EFFICIENCY (%)*	79	80
FLUE SIZE (MM)	100/150	100/150
ERP RATING	C	C



TRIMLINE BLACK OBSIDIAN

Are you hesitating between a freestanding fireplace and a built-in one? Then perhaps the Trimline Obsidian can win you over. Sit back and enjoy the flames, warmth, and ambiance of this freestanding fireplace, with the technology and look of a built-in appliance.

The Obsidian is available in white and in black and features Log Burner technology and an Anthracite Steel Interior.

WHAT'S INCLUDED:

- Burning Log Fuel Bed
- Anthracite Steel Interior
- Double Burner
- Ecomax Remote Control

OPTIONAL EXTRAS:

- Anti-reflective Glass
- Wifi Kit
- Remote Control Wall Mount
- Mains Adaptor

Interior Options:

- LED Fuel Bed
- Black Groove Interior

TECHNICAL INFO:

GAS TYPE	NG	LPG
HEAT INPUT (kW)	9.5	11.2
HEAT OUTPUT MAX (kW)	7.7	9.2
HEAT OUTPUT MIN (kW)	3.2	2.8
EFFICIENCY (%)*	82%	82%
FLUE SIZE (MM)	100/150	100/150
ERP RATING	B	B



TRIMLINE WHITE OBSIDIAN

Are you hesitating between a freestanding fireplace and a built-in one? Then perhaps the Trimline Obsidian can win you over. Sit back and enjoy the flames, warmth, and ambiance of this freestanding fireplace, with the technology and look of a built-in appliance.

The Obsidian is available in white and in black and features Log Burner technology and an Anthracite Steel Interior.

WHAT'S INCLUDED:

- Burning Log Fuel Bed
- Anthracite Steel Interior
- Double Burner
- Ecomax Remote Control

OPTIONAL EXTRAS:

- Anti-reflective Glass
- Wifi Kit
- Remote Control Wall Mount
- Mains Adaptor

Interior Options:

- LED Fuel Bed
- Black Groove Interior

TECHNICAL INFO:

GAS TYPE	NG	LPG
HEAT INPUT (kW)	9.5	11.2
HEAT OUTPUT MAX (kW)	7.7	9.2
HEAT OUTPUT MIN (kW)	3.2	2.8
EFFICIENCY (%)*	82%	82%
FLUE SIZE (MM)	100/150	100/150
ERP RATING	B	B



TRIMLINE OPAL

The Opal free-standing gas fire is a true statement piece. The rounded glass allows a 180° unrestricted view of the beautiful flames. The standard version has our Log Burner technology for an optimal flame experience, and an anthracite steel interior. On top of that, it comes with the Ecomax remote control and you have the options of adding wifi control with our Trimline Fires app.

WHAT'S INCLUDED:

- High Definition Logs
- Anthracite Steel Interior
- Double Burner
- Ecomax Remote Control

OPTIONAL EXTRAS:

- Anti-reflective Glass
- Wifi Kit
- Remote Wall Bracket

TECHNICAL INFO:

GAS TYPE	NG	LPG
HEAT INPUT (kW)	6.9	6.2
HEAT OUTPUT MAX (kW)	5.5	5.0
HEAT OUTPUT MIN (kW)	1.6	2.8
EFFICIENCY (%)*	79	84
FLUE SIZE (MM)	100/150	100/150
ERP RATING	C	B



TRIMLINE TOPAZ

The Topaz is not just a fireplace. This wall hanging appliance allows panoramic view of the flames, burning logs and LED fuel bed bringing you into an atmospheric environment. The Topaz has beautifully rounded corners and, in combination with its smooth lines, is a beautiful model that is a joy to the eye. The standard version of the Topaz has our log burner technology and a Anthracite Steel interior.

WHAT'S INCLUDED:

- Burning Log Fuel Bed
- Anthracite Steel Interior
- Double Burner
- Ecomax Remote Control

OPTIONAL EXTRAS:

- Wifi Kit
- Remote Control Wall Mount
- Mains Adaptor

Fuel Bed Options:

- LED Fuel Bed

TECHNICAL INFO:

GAS TYPE	NG	LPG
HEAT INPUT (kW)	6.8	6.5
HEAT OUTPUT MAX (kW)	5.3	5.2
HEAT OUTPUT MIN (kW)	3.7	3.8
EFFICIENCY (%)*	79	80
FLUE SIZE (MM)	100/150	100/150
ERP RATING	C	C



TECHNOLOGY

EVERYTHING YOU NEED IN ONE PACKAGE

Ecomax remote control

The sleek designed handset features a thermostatic control countdown timer to automatically turn off the fire, and an Ecomax button, allowing adjustment of the flames to regulate room temperature resulting in a 40% energy saving.

Adjustable legs

Allowing you to easily install the fire at your desired height without the need for further, unnecessary building work.

Control access door

A neat, gloss finish, access system to allow access to the manual fire controls.

Convection vents

Two of these are supplied with each fire to allow convected hot air from the chimney into your room.

DOUBLE BURNER (DB) FEATURE

With the exception of the TL38, TL60CF, TL85RD and selected Gemstone models with burning logs, all other Vision Trimline fires are equipped with an innovative double burner system. This clever feature staggers the flame pattern in two rows and gives an extra sense of depth and realism whilst offering a more economical way to use your fire. At the touch of a button the front burner row remains active whilst the rear burner row diminishes, giving unparalleled visual effect with a reduction of 40% of the heat output. Used in combination with the Ecomax remote control can result in the benefit of reduced running costs of up to 60%.

GO WI-FI FOR MAXIMUM CONTROL

Introducing the latest optional upgrade option for Vision Trimline fires, the Myfire app uses wireless technology that connects the fire to your home Wi-Fi network. You can now take control using your smartphone or tablet with features such as:

- Temperature adjustment and thermostatic control
- Flame pattern adjustment and animated wave profiles
- Individual user profiles
- Countdown timer
- Weekly programming

ANTI-REFLECTIVE GLASS

Anti-reflective glass (ARG) which is available on many Vision Trimline models is a premium feature that allows you to maximise your experience of the beautiful flames giving the appearance of an open fire whilst having the convenience of a gas appliance. This clever feature gives the illusion that there is no glass between the fire and you, creating an even more authentic experience.

BURNING LOGS TECHNOLOGY

Available on TL55, TL64, TL83, and selected Gemstone models, the burning logs technology recreate the most authentic, realistic looking flame ever. Combined with high definition, ultra realistic ceramic logs, this innovative feature creates a fire so realistic it cannot be distinguished from a natural, living fire. For the ultimate in warm ambiance, the optional LED glowing fuel bed creates a subtle, relaxing impression of gently burning embers.



INTERIOR STYLING & FUEL BED OPTIONS

For that extra WOW factor, why not choose to upgrade to a black mirrored glass lining for your fire chamber and add a reflection to the fuel bed and flames to give a remarkable effect of added depth and detail. If burning logs is not the look you are going for, then perhaps you would be more interested in an alternative fuel bed for your fire. The collection features a range of stunning options to choose from.

LAMEL INTERIOR



BLACK GROOVE INTERIOR



VERMICULITE INTERIOR



INTERIOR GREY BRICK



BLACK GLASS INTERIOR



REEDED PANEL



FIRE BRICK INTERIOR



HIGH DEFINITION LOG SETS



WHITE PEBBLES



CARRARA STONES



BASALT



TL70SL UPGRADE OPTIONS

For that extra WOW factor, there is also an option to upgrade to a black glass lining within the combustion chamber which offers a remarkable effect of added depth and detail. Other available upgrades also include Wi-Fi, vermiculite interior lining and alternative frame options.

BLACK GLASS UPGRADE



VERMICULITE BRICKS UPGRADE



FLUE SYSTEMS

All Vision Trimline fires (excluding the TL60CF) use a specialised double wall concentric flue system. The Holetherm system is an obligatory and integral part of the complete combustion system and must be used when installing the fire. concentric flue is made of high quality 0.5mm thick stainless steel AISI 316 inner and AISI 304 outer-liner.

A wide range of flue/chimney components allows for easy installation when terminating through the wall or the roof in an existing chimney or a dedicated fabrication. Please consult your nearest dealer for more details. The Holetherm system is approved according to CE in combination with all Vision Trimline balanced flue gas fires.

New to the Vision Trimline range is the DECO concentric flue system, for use with the Gemstone Series. Elegant connecting pipes with no visible locking bands available in black coated stainless steel. Both the design and ease of installation are of a very high standard. The connection of the various sections and elements is carried out by means of a click connection with the cam spring. Turn the flue to the correct position and when you hear the "click" it is already securely attached. It has never been so easy to quickly install a beautiful connecting pipe!

The DECO system is the first and only system that works with this unique click connection and is made of high-quality stainless steel material and is resistant to high temperatures and flue gases.



DIMENSIONS

TL38 FRONT

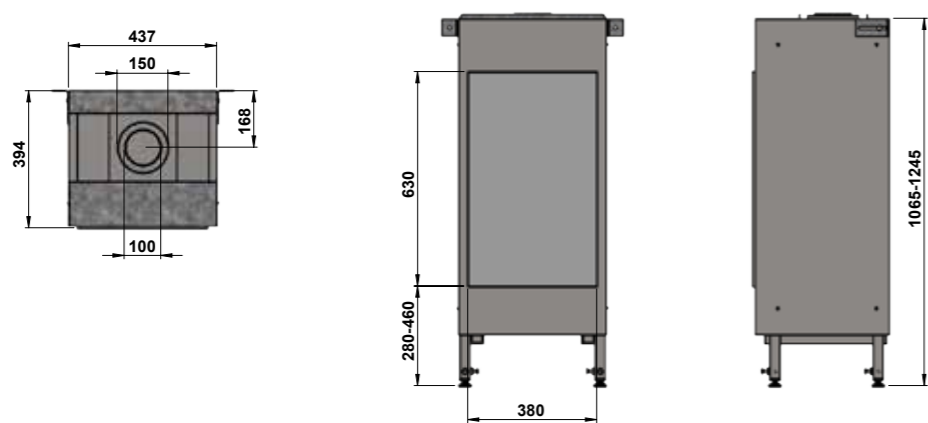

TL55XH

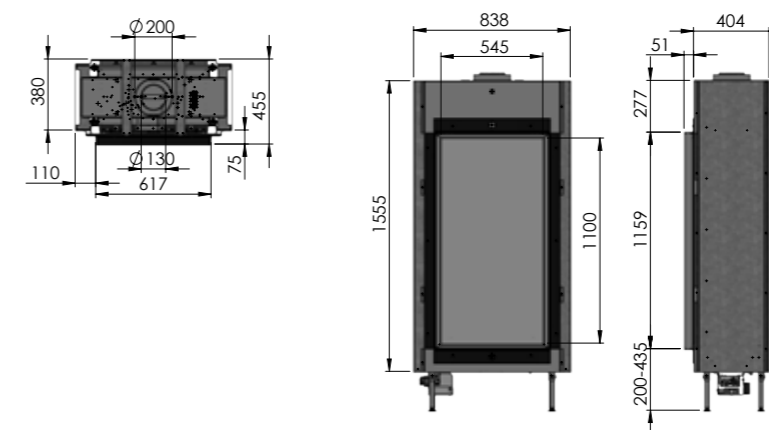

TL38 CORNER

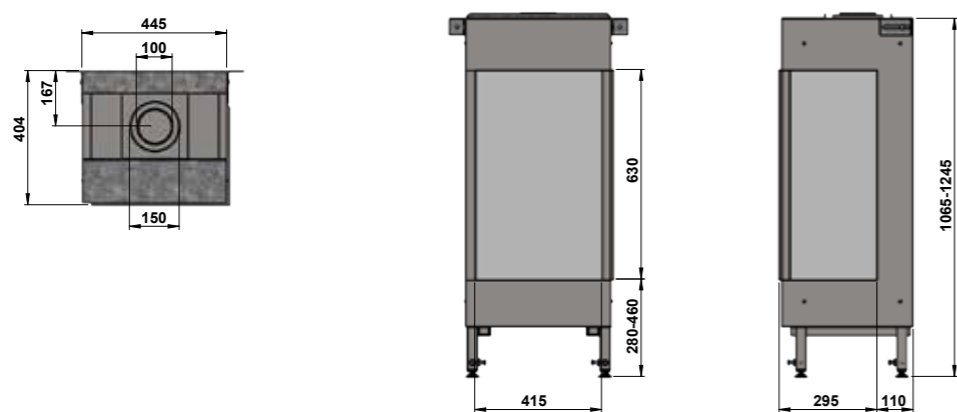

TL55XH TUNNEL

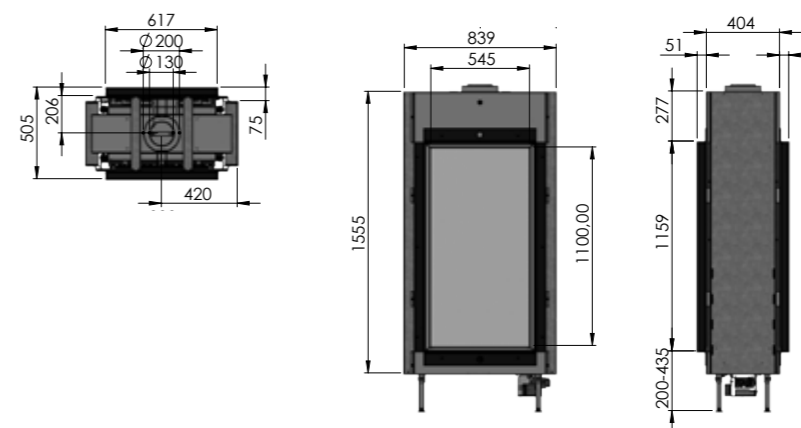

TL38 PANORAMIC

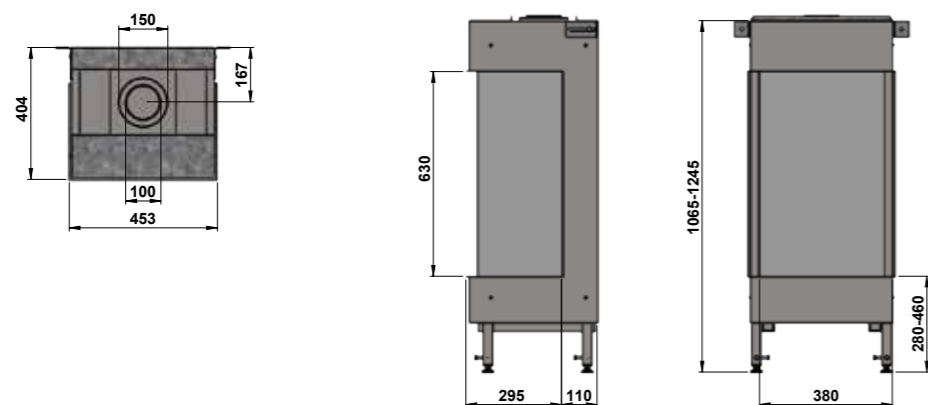

TL60CF

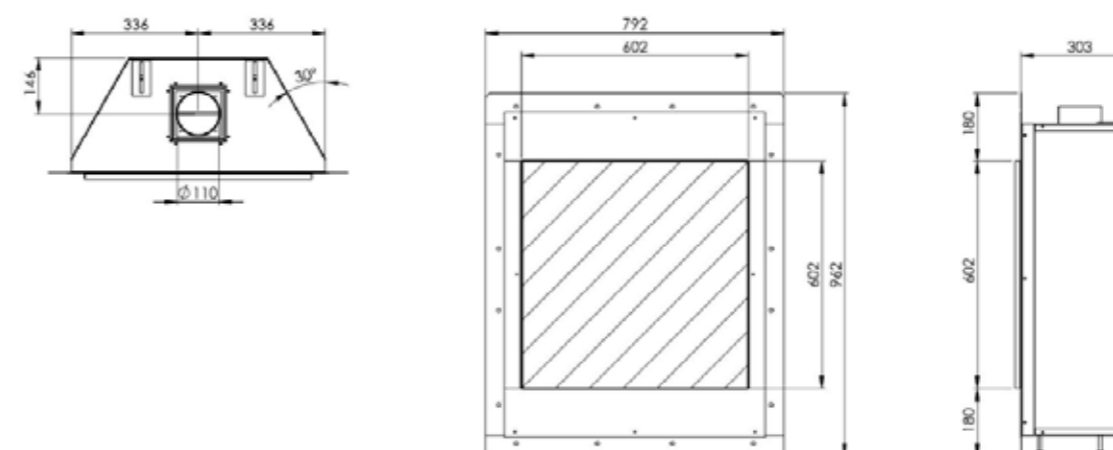

DIMENSIONS

TL64 FRONT

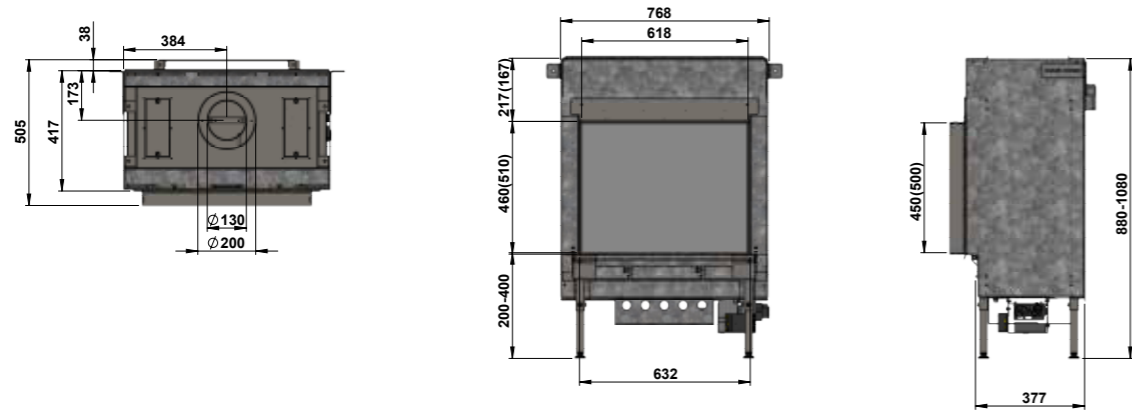

TL70SL

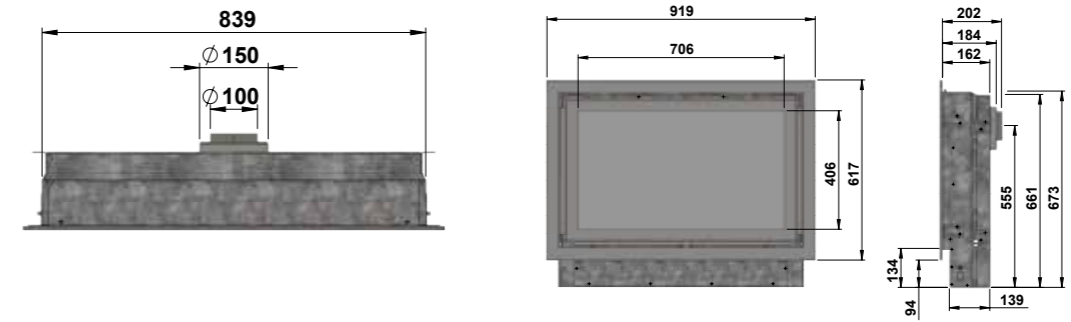

TL64 CORNER

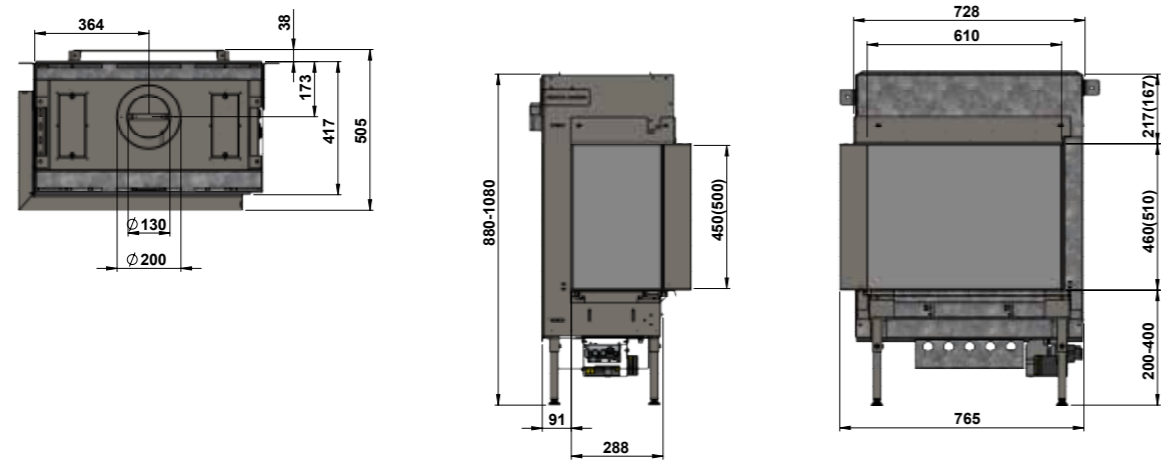

TL70SL PANACEA

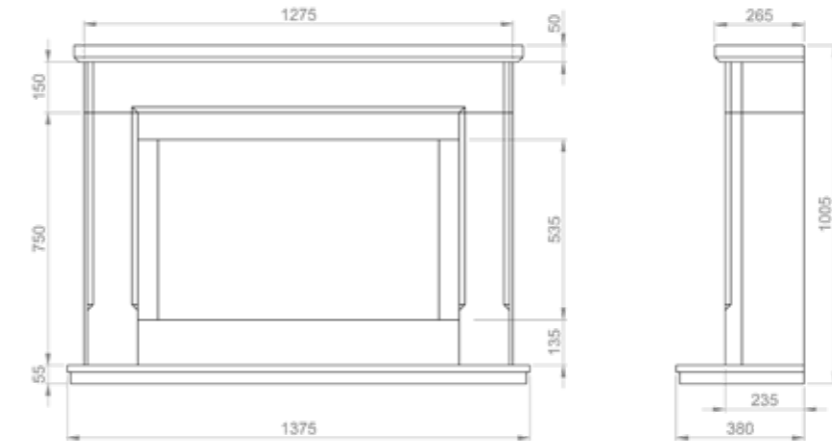

TL64 PANORAMIC

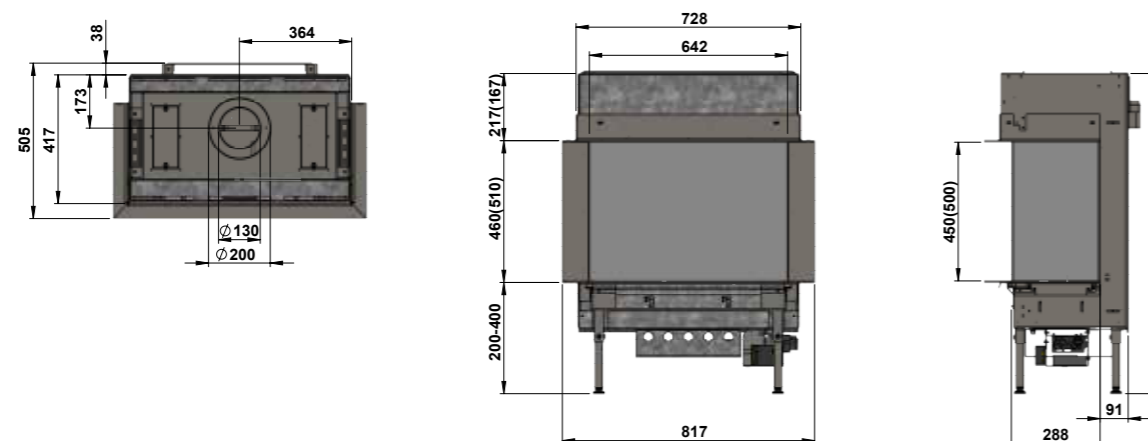

TL70SL HAMPTON

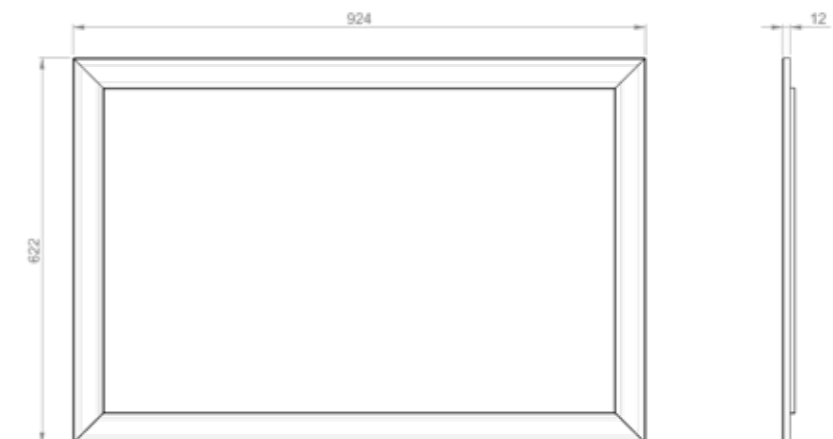

DIMENSIONS

TL70SL RADLEY

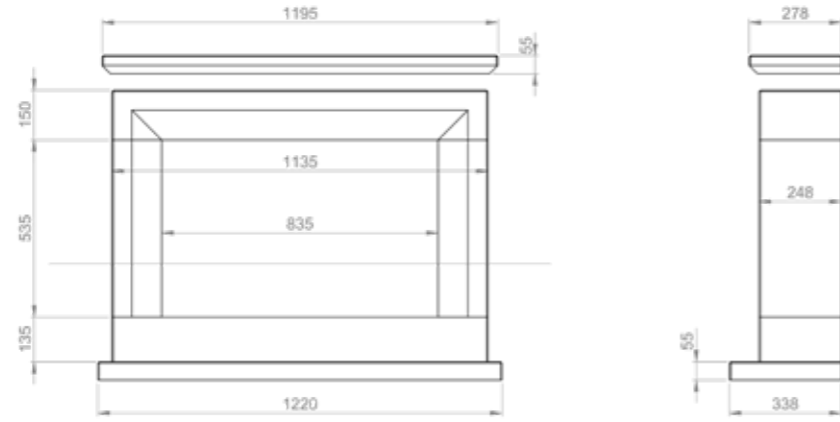

TL73 ROOM DIVIDER

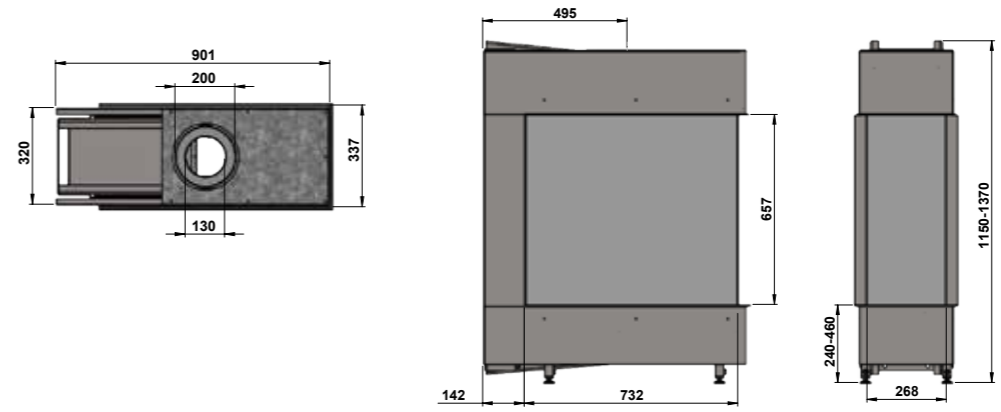

TL70SL RICO

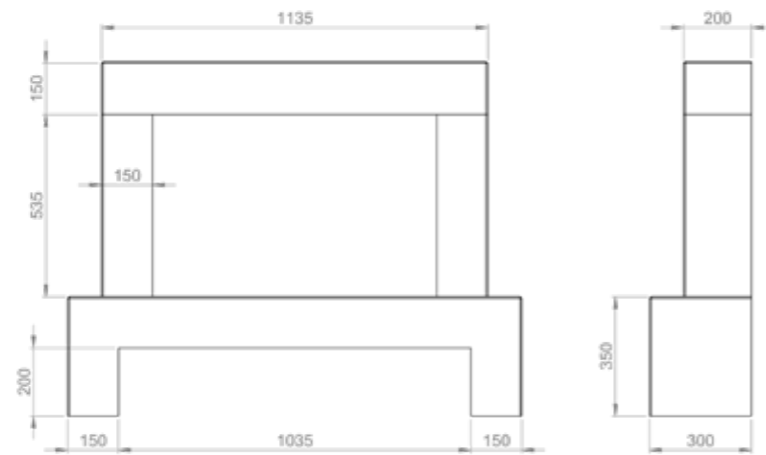

TL73H FRONT

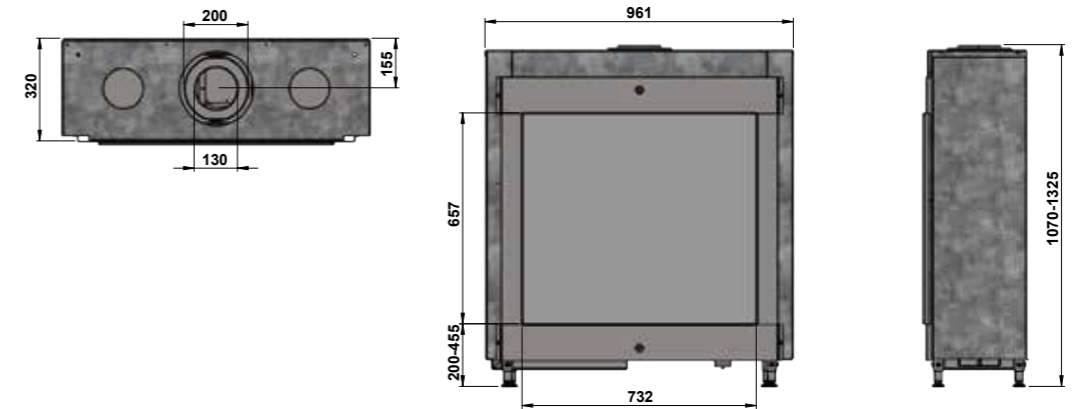

TL73 FRONT

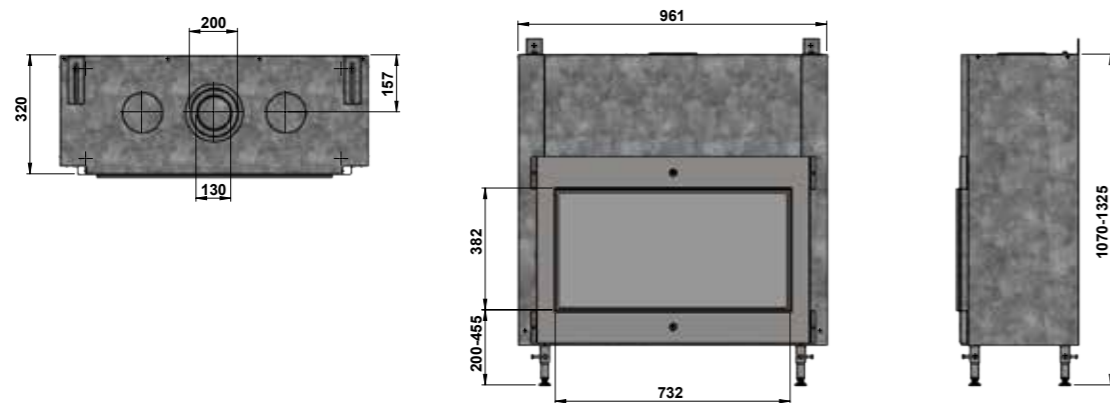

TL73H TUNNEL

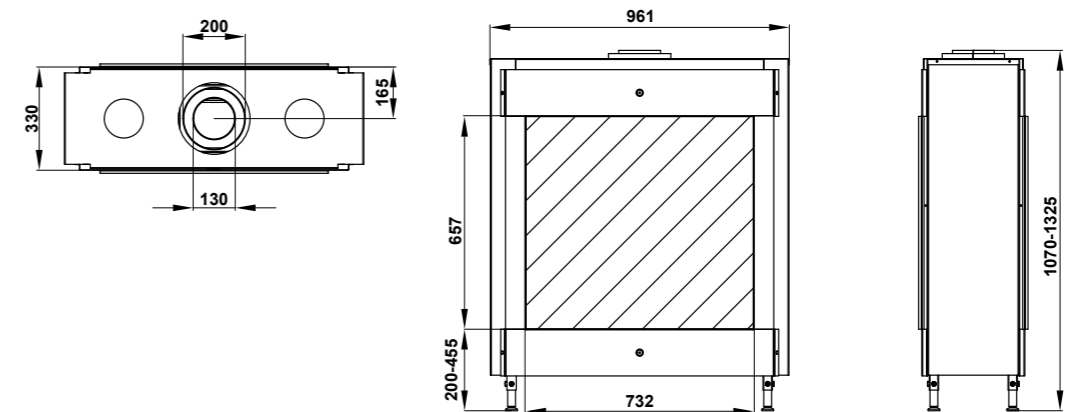

DIMENSIONS

TL83 FRONT

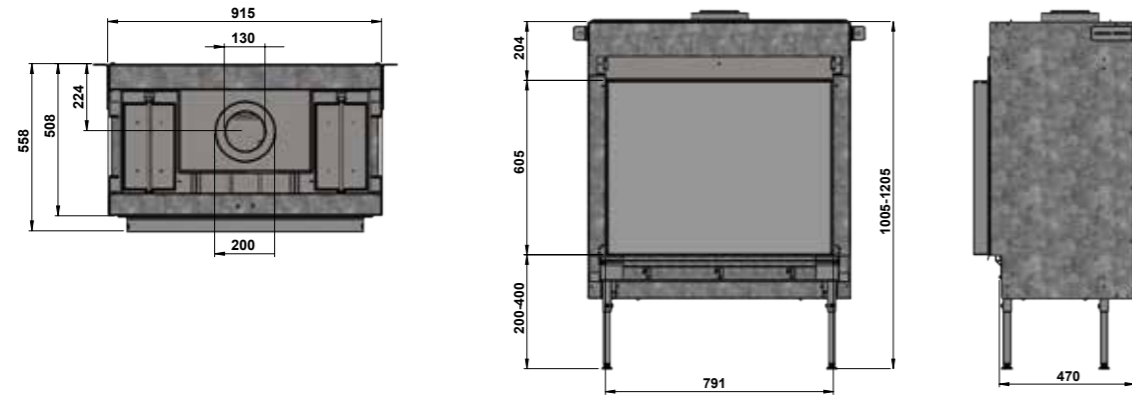

TL83 TUNNEL

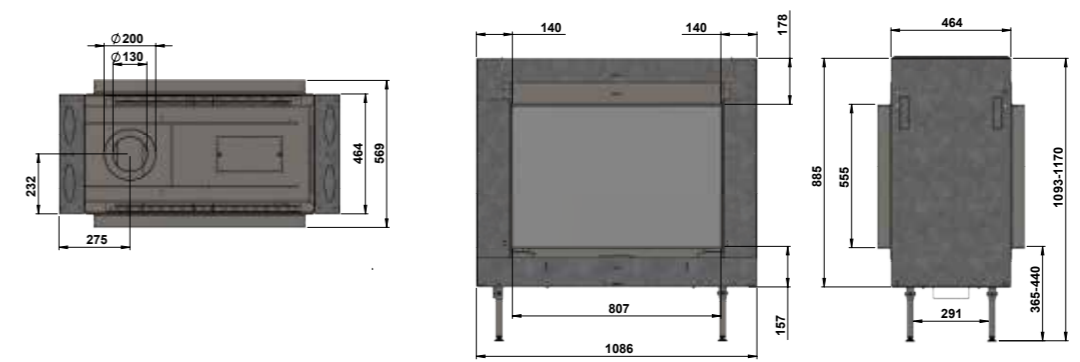

TL83 CORNER

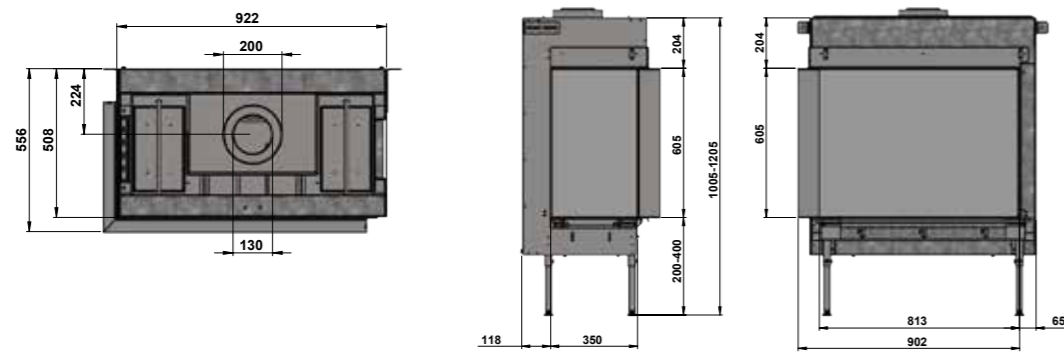

TL83 ROOM DIVIDER

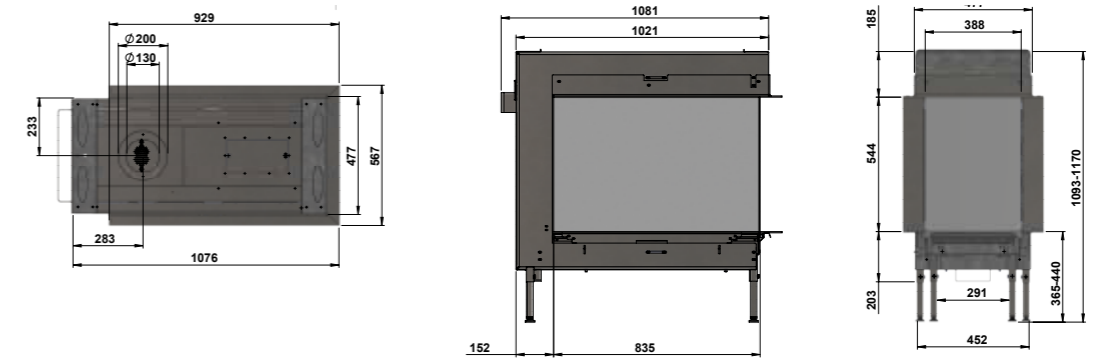

TL83 PANORAMIC

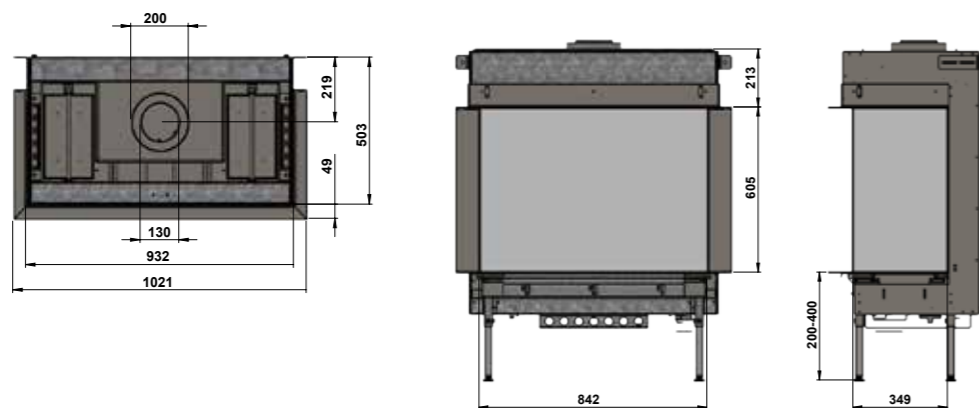

TL85 ROOM DIVIDER

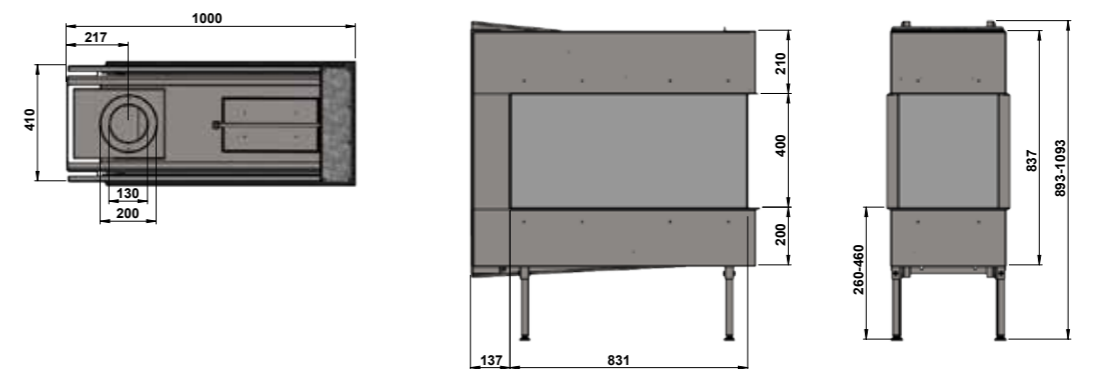

DIMENSIONS

TL100 FRONT

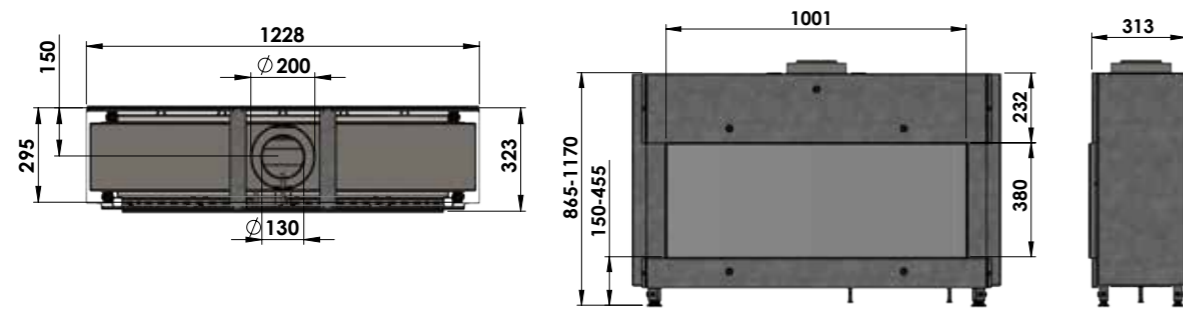

TL100 TUNNEL

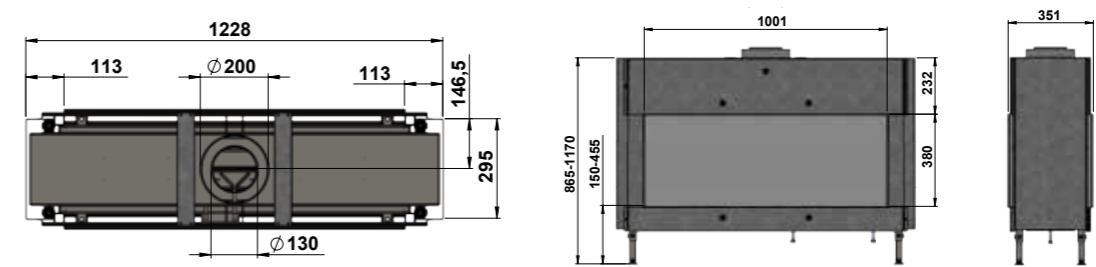

TL100 CORNER

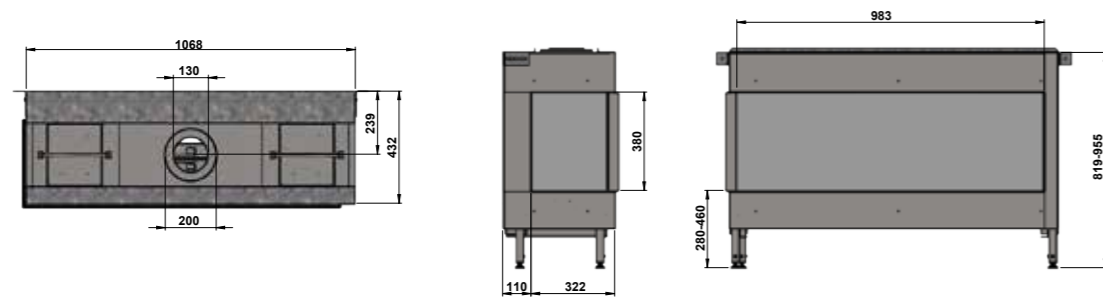

TL120 FRONT

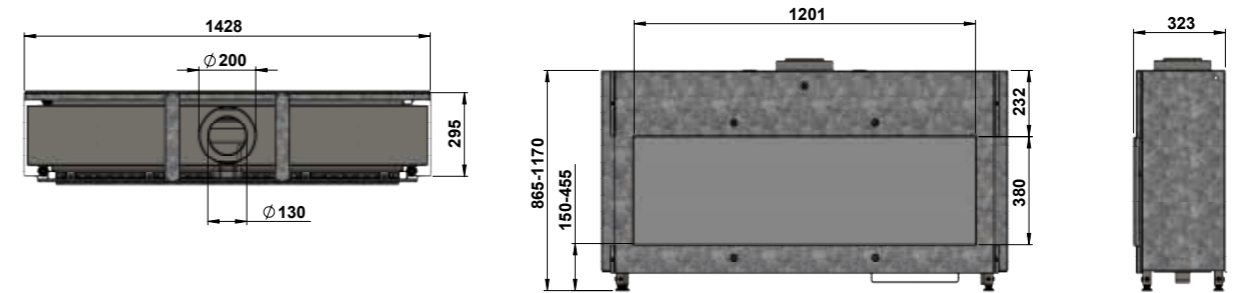

TL100 PANORAMIC

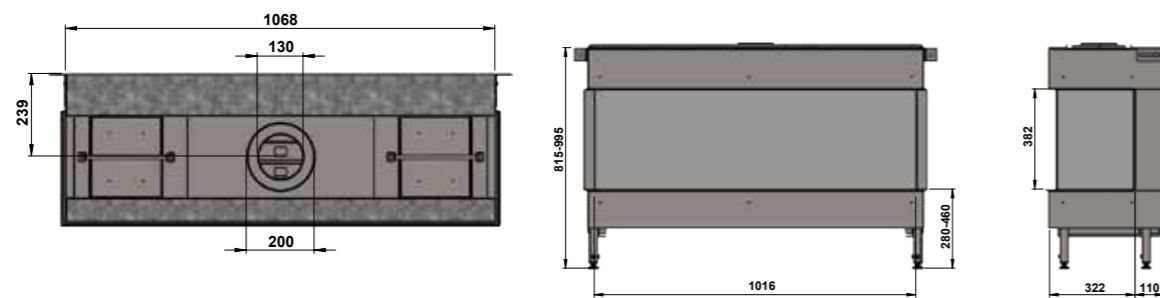

TL120 CORNER

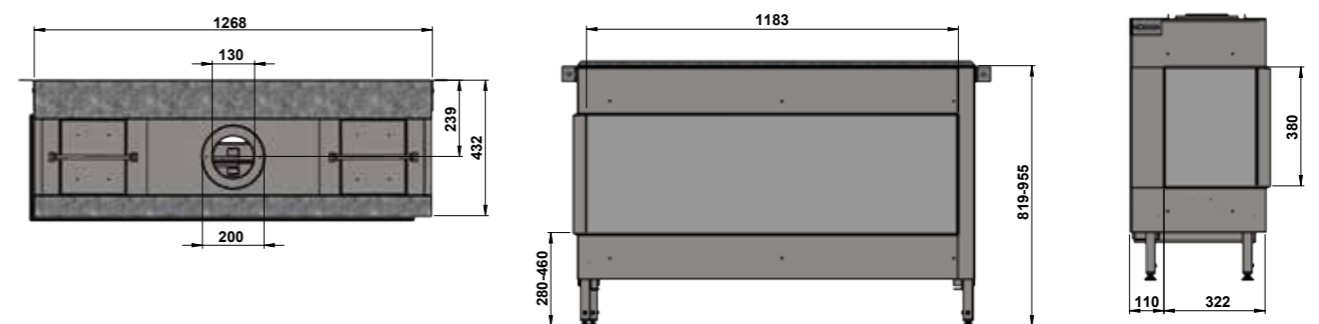

DIMENSIONS

TL120 PANORAMIC

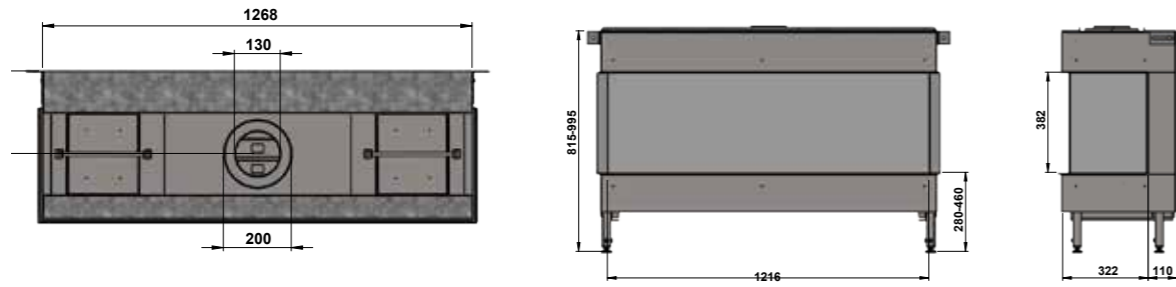

TL140 CORNER

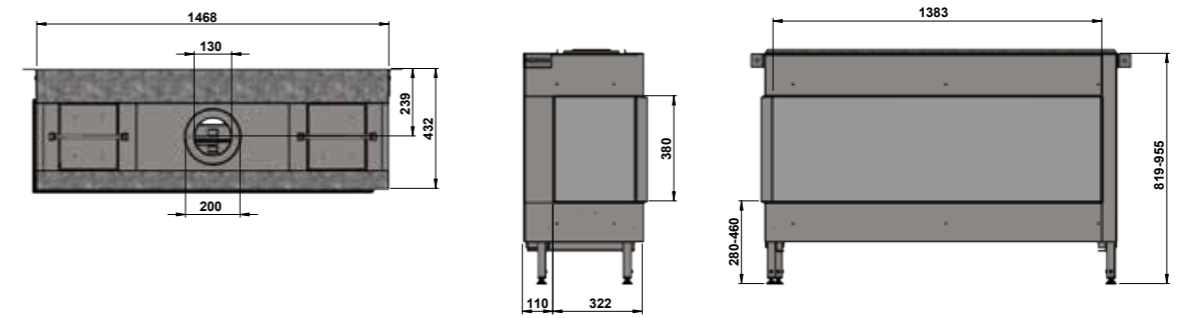

TL120 TUNNEL

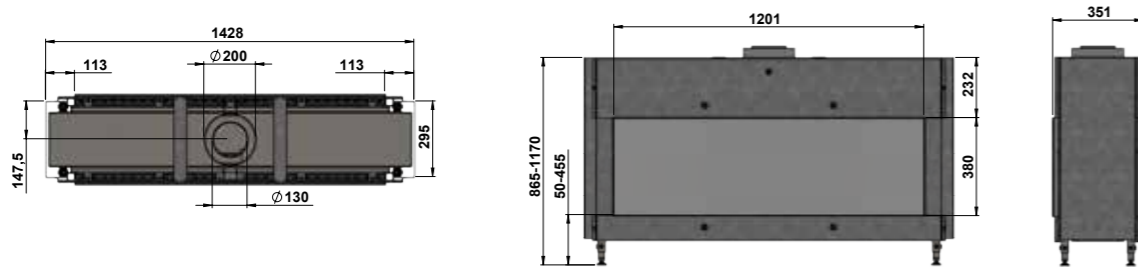

TL140 PANORAMIC

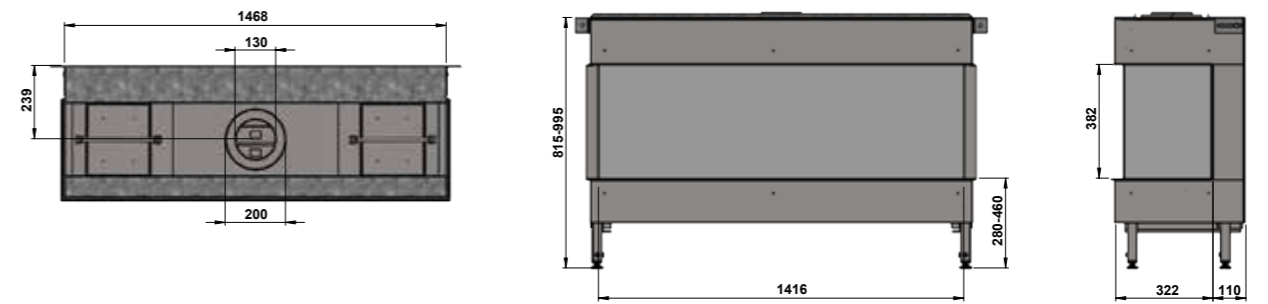

TL140 FRONT

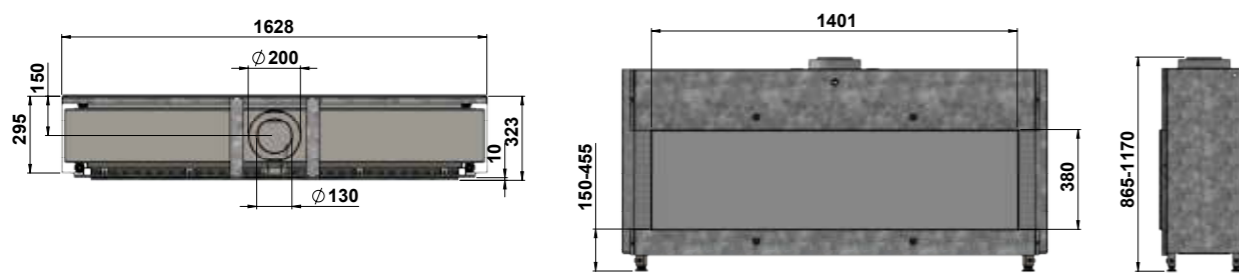

TL140 TUNNEL

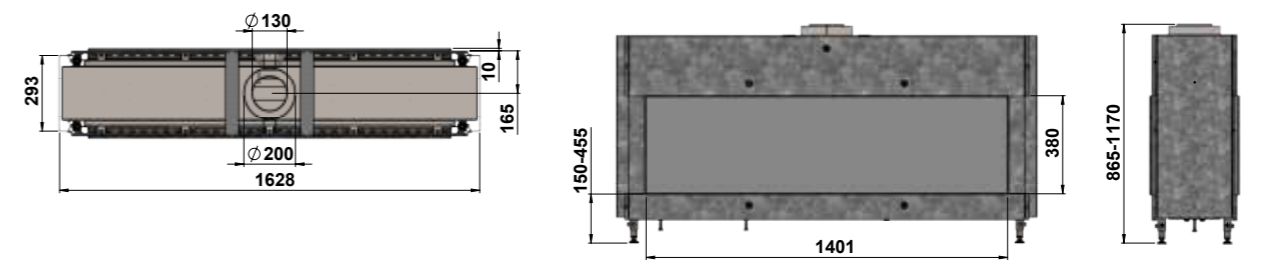

DIMENSIONS

TL170

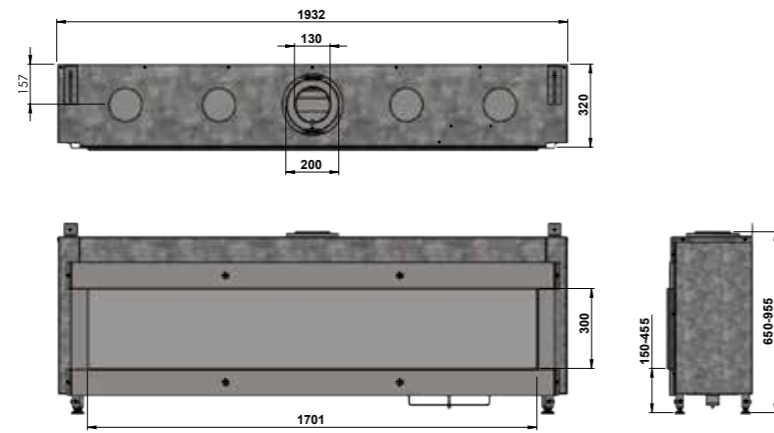

TRIMLINE QUARTZ

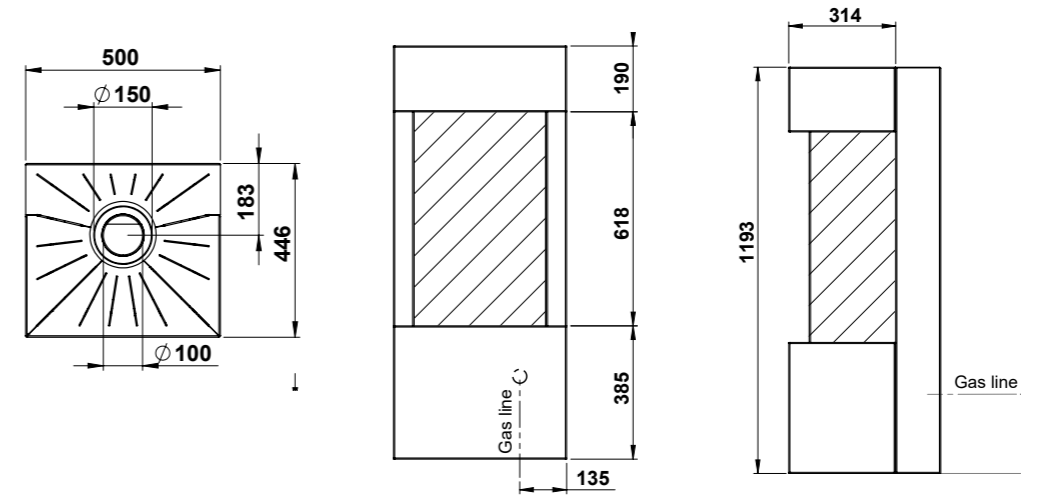

TL170H

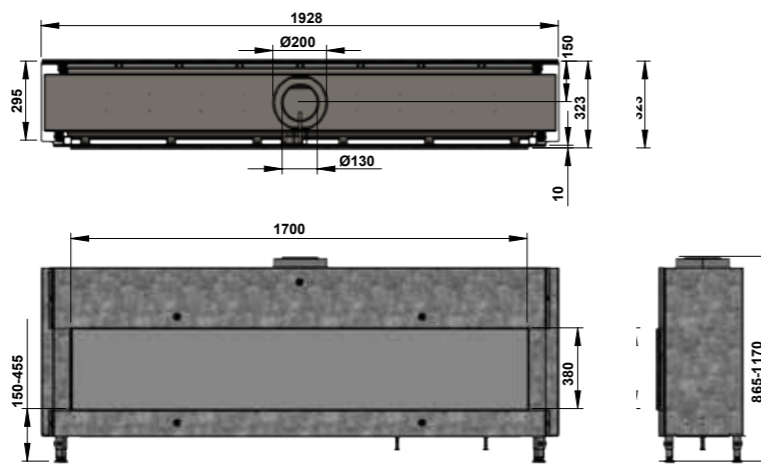

TRIMLINE ZIRCON

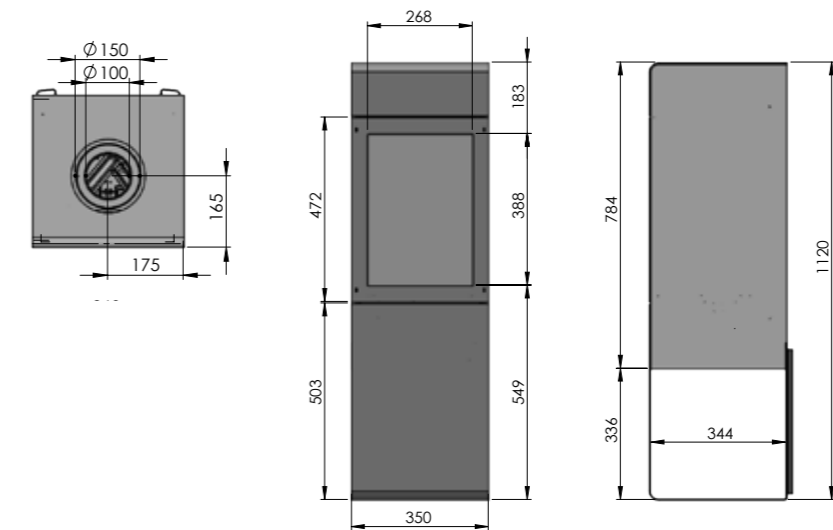

TL2050

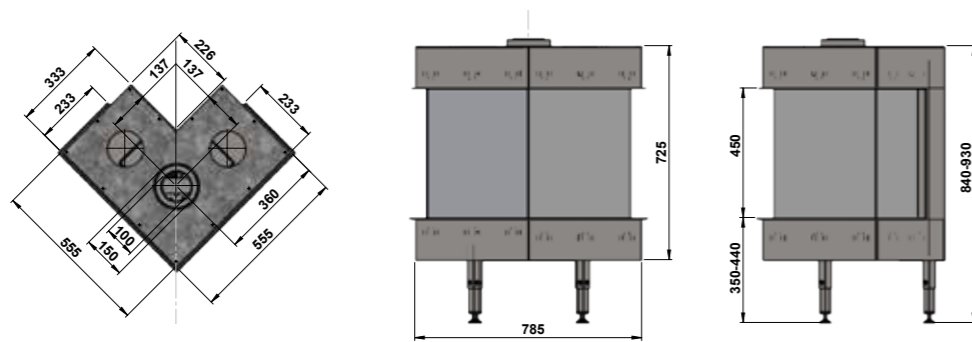

TRIMLINE TOURMALINE

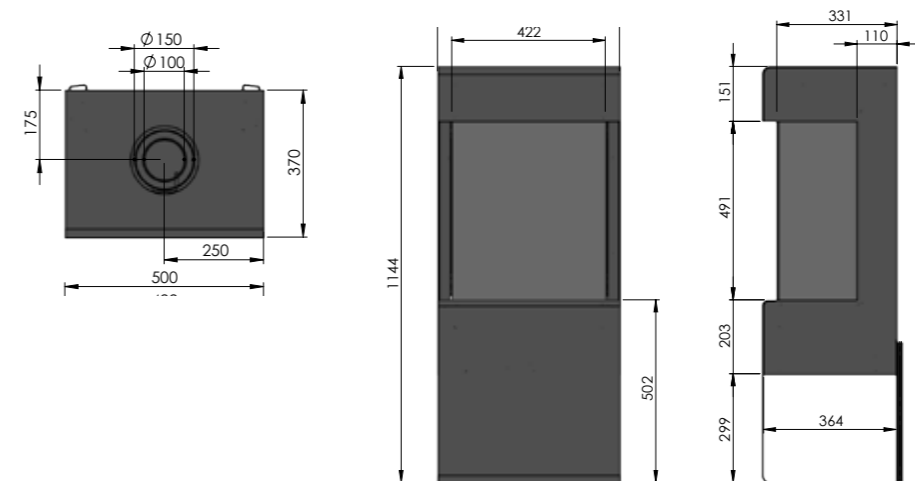

DIMENSIONS

TRIMLINE OBSIDIAN

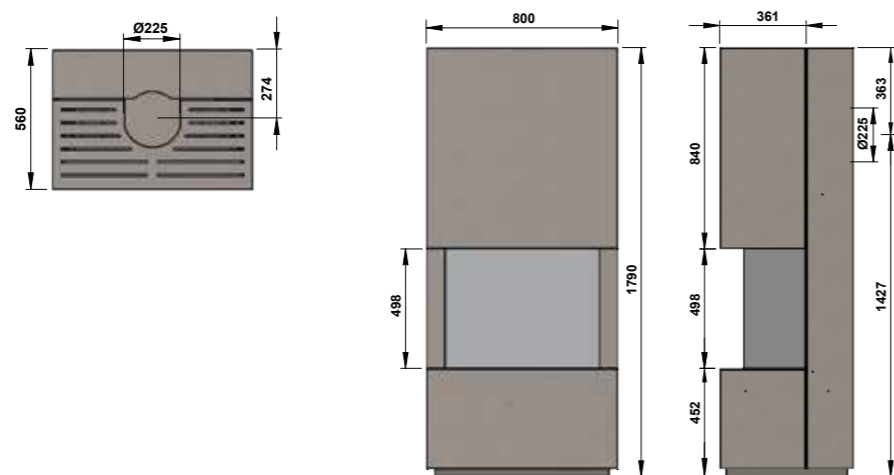

TRIMLINE OPAL

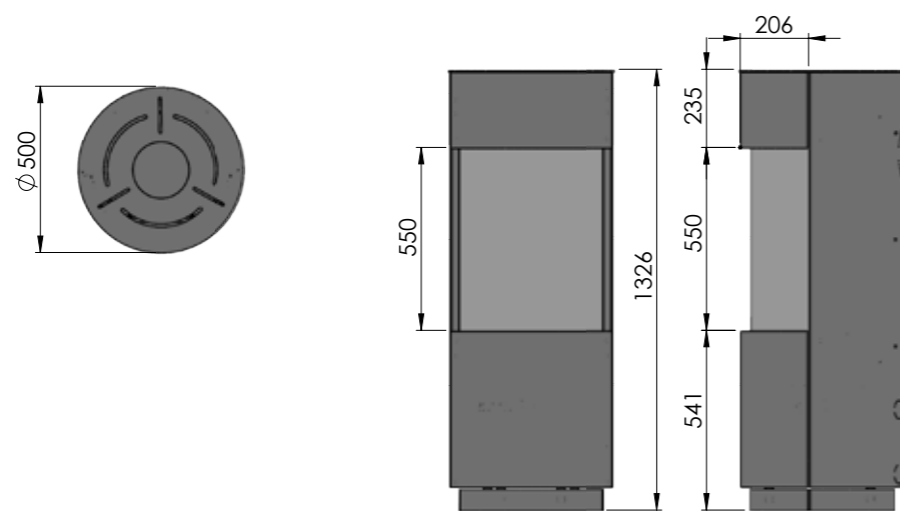

TRIMLINE TOPAZ

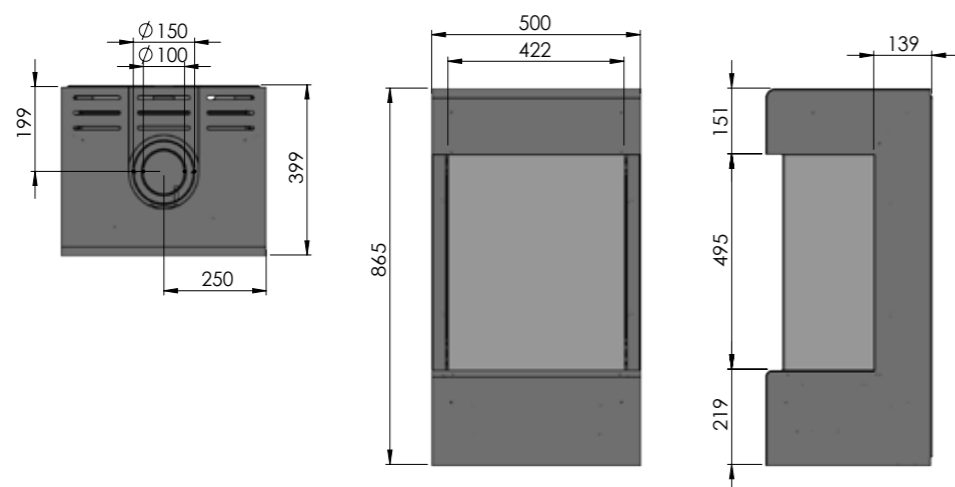



www.visionfires.co.uk

01204 868 550

info@visionfires.co.uk